

# **E-ZLIFT 4" Belt Bucket Conveyor BB-050-4**

**with Direct Drive for 10" Wide Belt**

**Parts List & Schematic**

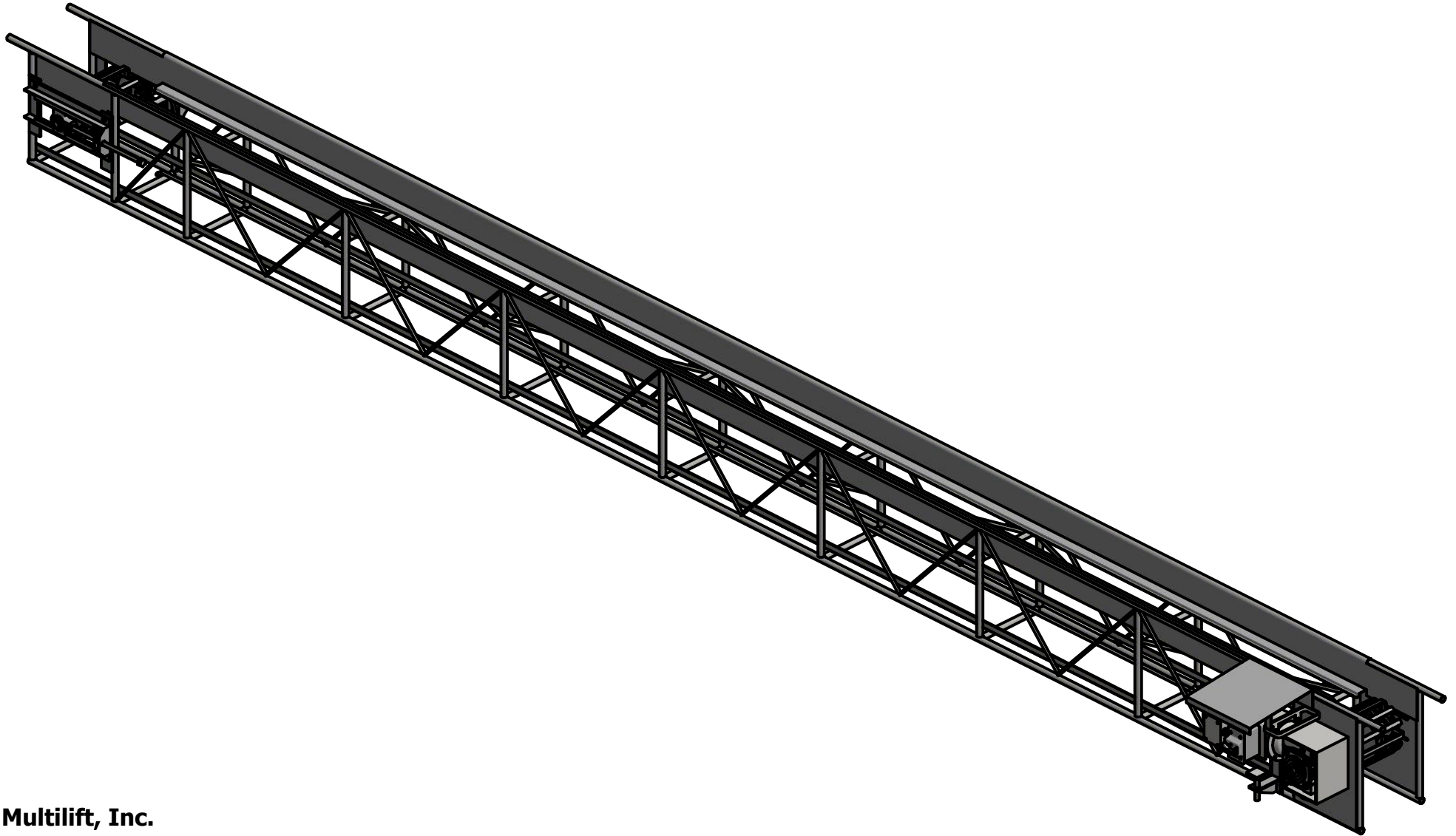

**Multilift, Inc.**

Denver, CO USA

[www.ezliftconveyors.com](http://www.ezliftconveyors.com)

North American Toll Free: 1-800-821-9966

Denver Local: 303-733-5533

**Model BB-050-4  
Driven End**

Part#	Description
127	Drive Pulley w/ 1" bore
148F	Drive Shaft w/ 1" O.D.
149	1" Bearing w/ 3-hole Triangular Flangettes
149A	1" Bearing w/ Rectangle/Oval Flangettes
157	Handle for Motor/Reducer Assembly
157G	Direct Drive Motor Guard (with #157 handle)
162	Boot Mount for Size 50 Reducer
175B-BM	Boot Mount for Size 60 Reducer
175A	Size 50 Reducer w/ 1" hollow bore
175B-30 1"	Size 60 Reducer w/ 1" hollow bore
175MSH	Motor Support Hardware
193	1 hp 115V 56C TEFC motor
193TR	Thermal Reset Button for Baldor 1 hp 3510M motor
194	1-1/2 hp 115V 56C TEFC motor
194TR	Thermal Reset Button for Baldor 1-1/2 hp 3514M motor
195B	Start/Stop switch
203	4" Side Pan x 8 ft. long
Rubber cover	Rubber Cover for Thermal Reset

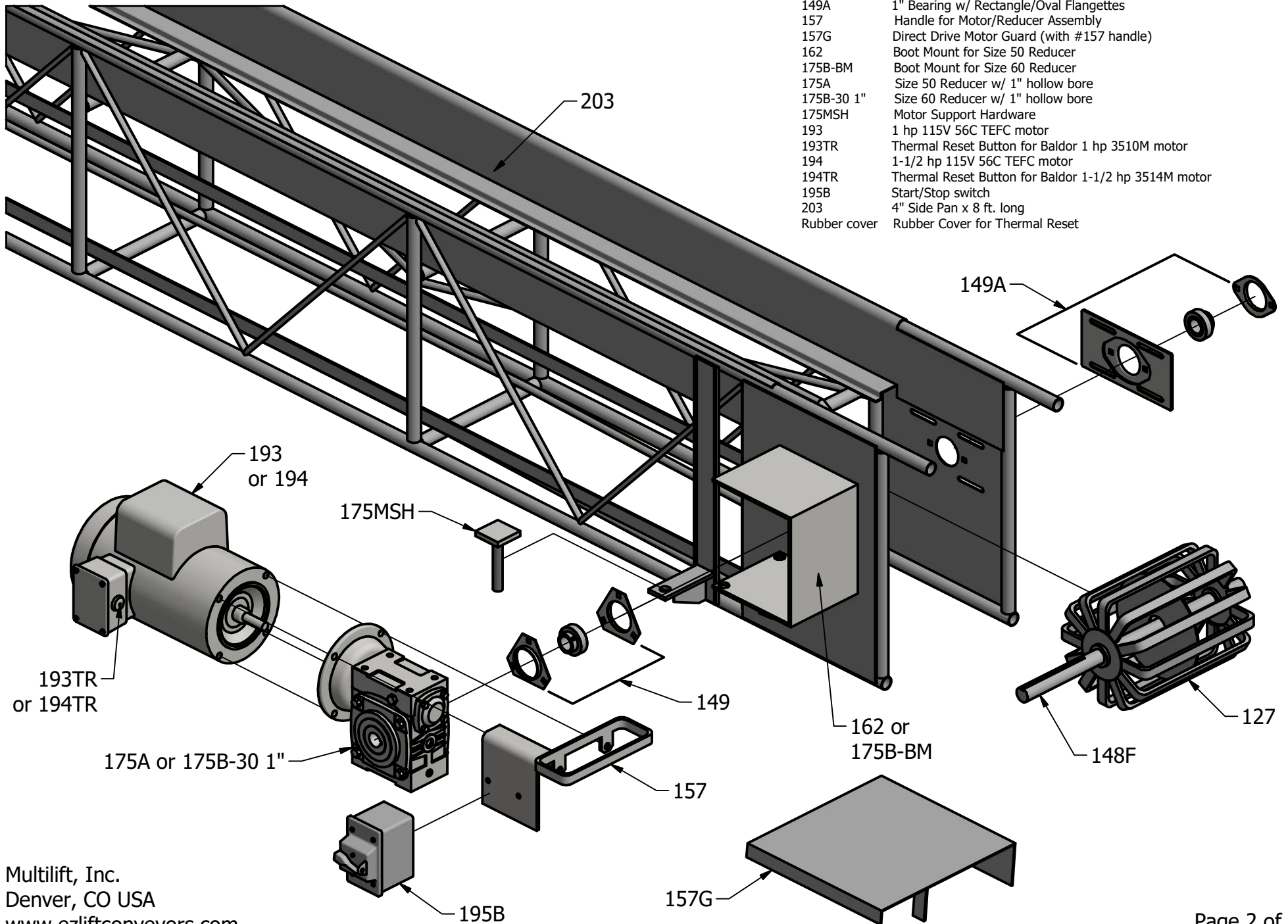

**Model BB-050-4**  
**Idle End**

Part#	Description
129	Tail Pulley w/ 1" bore
148B	Tail Shaft w/ 1" O.D.
216	Adjustment housing w/ 1" bearing
216A	1" Bearing insert for housing
217	Adjustment frame w/ screw for 1" bearing
220	5/8" All-thread screw for adjustment frame

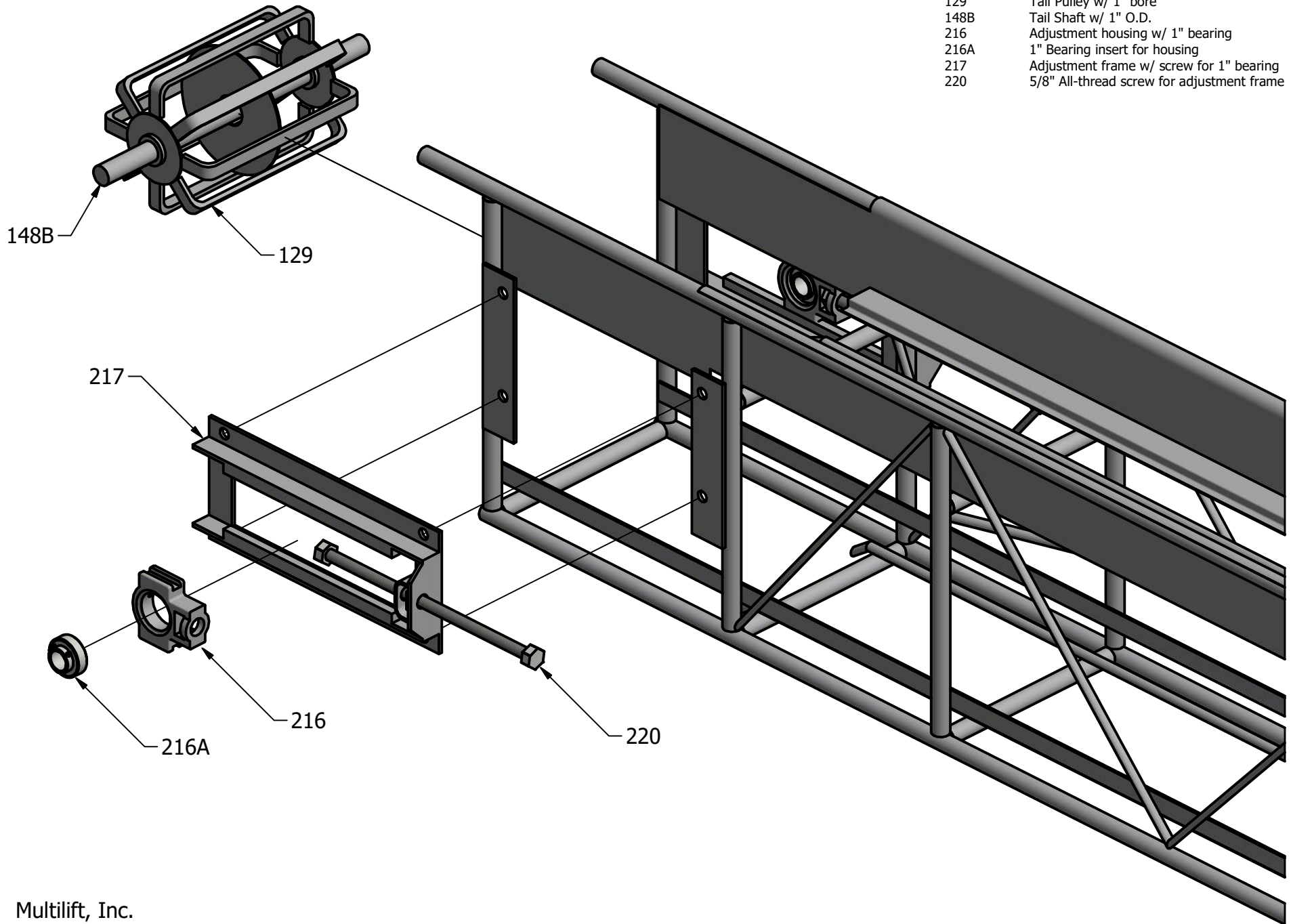

# E-ZLIFT 4" Belt Bucket Conveyor BB-050-4

## Full Parts List Including Belting and Lacing

Part#	Description
127	Drive Pulley w/ 1" bore
148F	Drive Shaft w/ 1" O.D.
149	1" Bearing w/ 3-hole Triangular Flangettes
149A	1" Bearing w/ Rectangle/Oval Flangettes
157	Handle for Motor/Reducer Assembly
157G	Direct Drive Motor Guard (with #157 handle)
162	Boot Mount for Size 50 Reducer
175B-BM	Boot Mount for Size 60 Reducer
175A	Size 50 Reducer w/ 1" hollow bore
175B-30 1"	Size 60 Reducer w/ 1" hollow bore
175MSH	Motor Support Hardware
193	1 hp 115V 56C TEFC motor
193TR	Thermal Reset Button for Baldor 1 hp 3510M motor
194	1-1/2 hp 115V 56C TEFC motor
194TR	Thermal Reset Button for Baldor 1-1/2 hp 3514M motor
195B	Start/Stop switch
203	4" Side Pan x 8 ft. long
Rubber cover	Rubber Cover for Thermal Reset Button

Part#	Description
129	Tail Pulley w/ 1" bore
148B	Tail Shaft w/ 1" O.D.
216	Adjustment housing w/ 1" bearing
216A	1" Bearing insert for housing
217	Adjustment frame w/ screw for 1" bearing
220	5/8" All-thread screw for adjustment frame

### Belt Parts

Part#	Description
106	Bucket assembly
106A	4" belt strap for bucket
106B	Steel strap for 4" bucket
222	10" wide belting / ft.
325-M10-10	Set of 10" long Screw Lacing w/ 10mm screws
326-10	Set of #RS187 x 10" long Staple Lacing*

### Complete Belt Assemblies w/ 4" Buckets

Part#	Description
210-12	12 ft. #38 conveyor
210	16 ft. #40 conveyor
211	21 ft. #41 conveyor
212	26 ft. #43 conveyor
213	31 ft. #45 conveyor
214	36 ft. #47 conveyor

\* requires #326-4 tool for assembly

