

E-ZLIFT Top Side Mount 2" Belt Bucket Conveyor BB-050-TSM

Parts List & Schematic

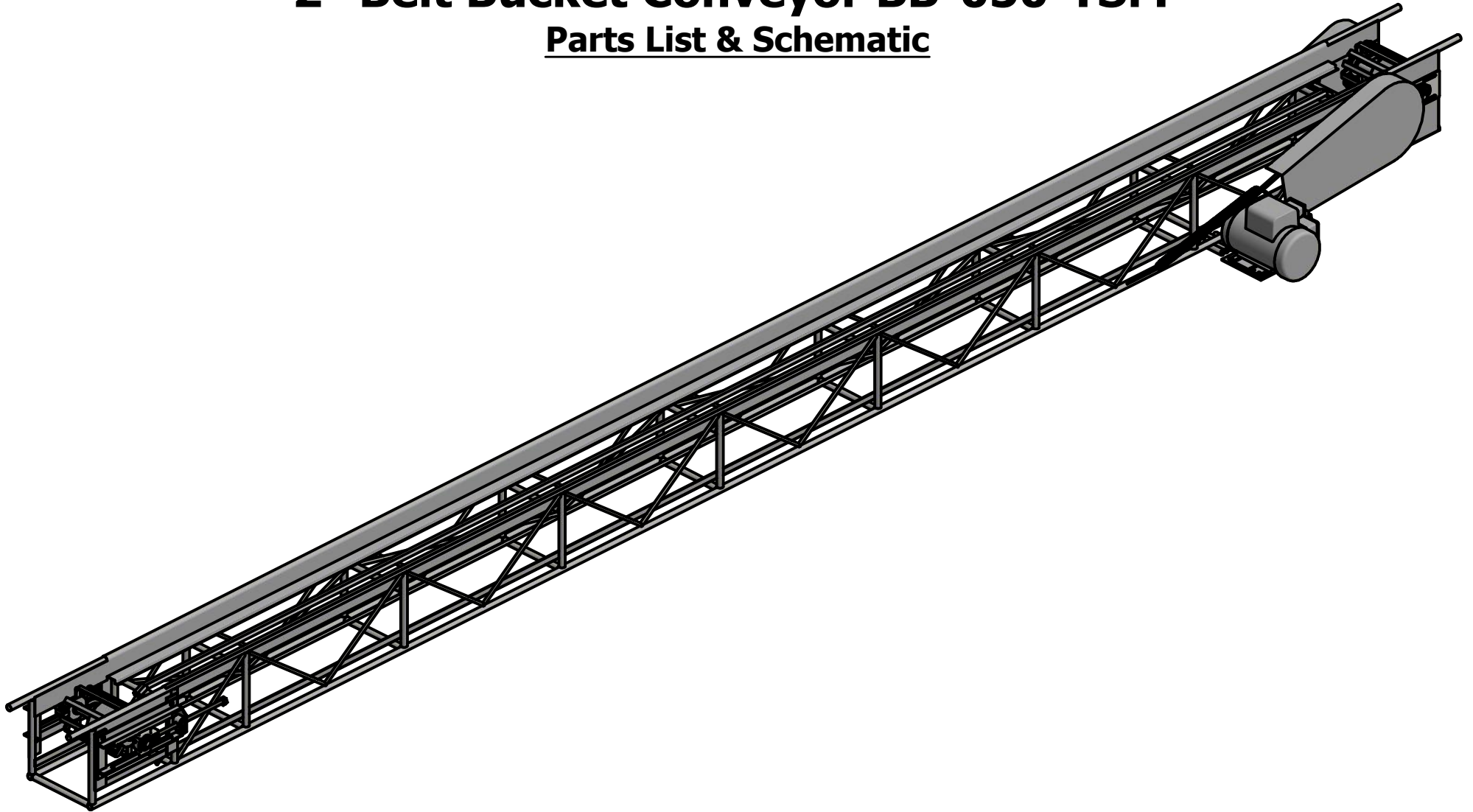

Multilift, Inc.

Denver, CO USA

www.ezliftconveyors.com

North American Toll Free: 1-800-821-9966

Denver Local: 303-733-5533

**Model BB-050-TSM
Driven End**

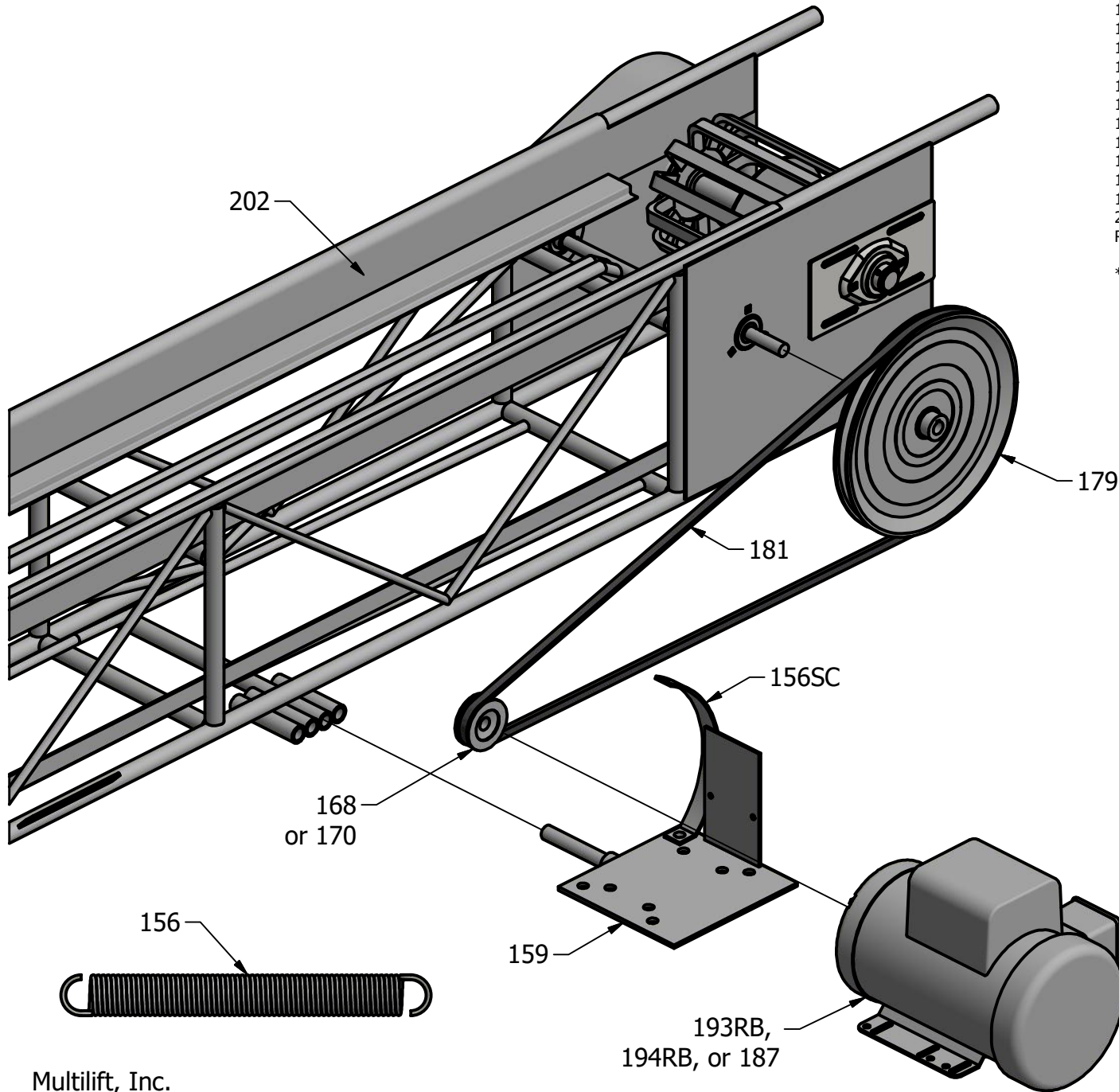

Part#	Description
156	Motor tension spring
156SC	Spring Clip
159	Motor Mount
168	2-1/2" O.D. x 1/2" bore B pulley (for electric motor)
170	2-1/2" O.D. x 5/8" bore B pulley (for gas engine)
179	11" O.D. x 5/8" bore v-belt Pulley
181	5L1000/B67 V-Belt
187	5-1/2 hp Honda gas engine
190A	V-Belt guard
193RB	1 hp 115V 56C TEFC rigid base motor
193TR	Thermal Reset Button for Baldor 1 hp 3510M motor*
194RB	1-1/2 hp 115V 56C TEFC rigid base motor
194TR	Thermal Reset Button for Baldor 1-1/2 hp 3514M motor*
202	2" Side Pan x 8 ft. long
Rubber cover	Rubber Cover for Thermal Reset*

* Not shown

**Model BB-050-TSM
Driven End**

Part#	Description
128	Drive Pulley w/ 1" bore
130	Section of #40 roller chain (77 pitches)
134D	5/8" O.D. Secondary Drive Shaft
141	11-tooth Sprocket w/ 5/8" bore for #40 roller chain
145	60-tooth Sprocket w/ 1" bore for #40 roller chain
146	Chain guard
148C	1" O.D. Drive Shaft
149	1" Bearing w/ 3-hole Triangular Flangettes
149A	1" Bearing w/ Rectangle/Oval Flangettes
153	5/8" Bearing w/ 3-hole Round Flangettes
195B	Start/Stop switch

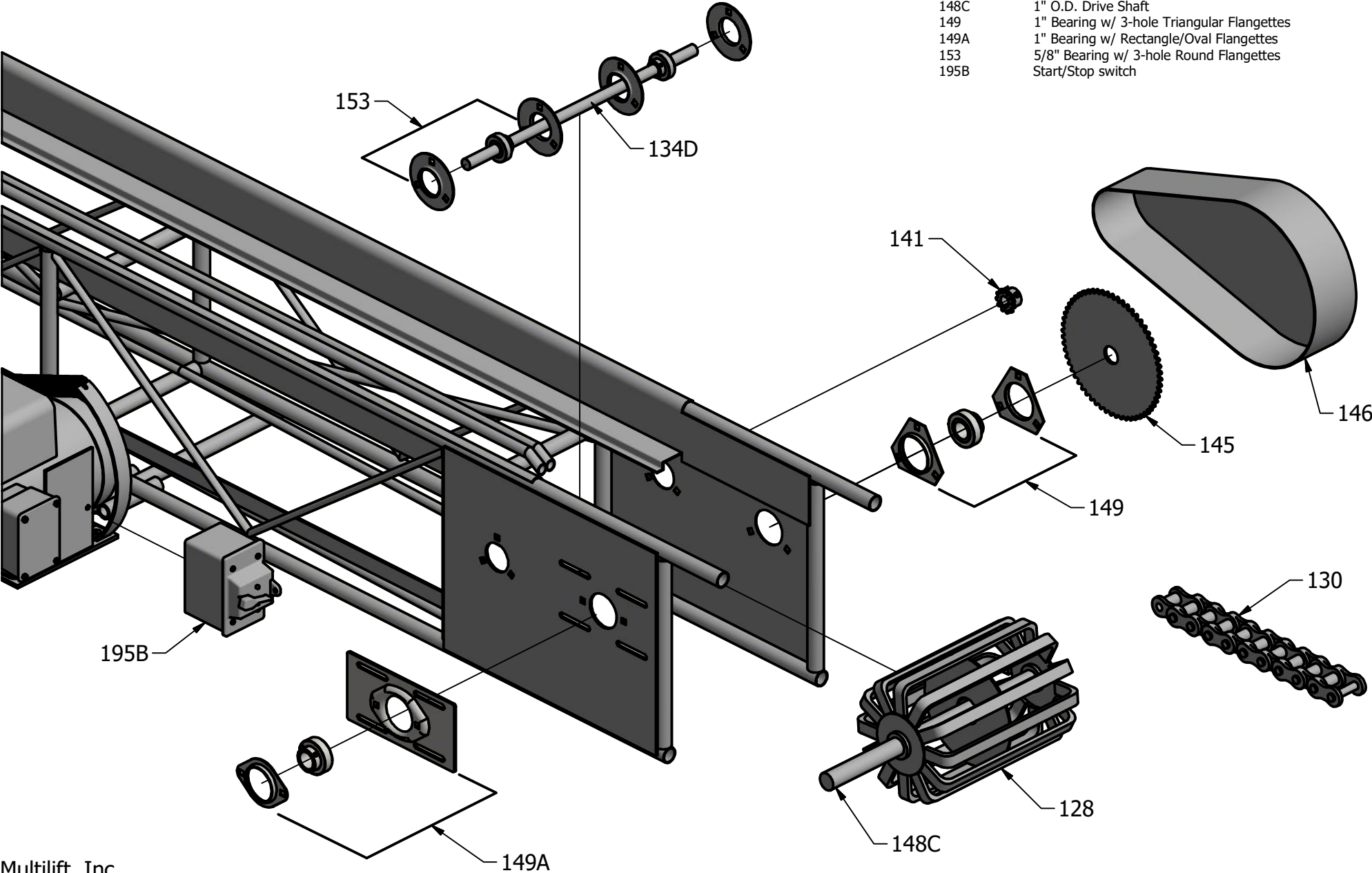

Model BB-050-TSM
Idle End

<u>Part#</u>	<u>Description</u>
129	Tail Pulley w/ 1" bore
148B	Tail Shaft w/ 1" O.D.
216	Adjustment housing w/ 1" bearing
216A	1" Bearing insert for housing
217	Adjustment frame w/ screw for 1" bearing
220	5/8" All-thread screw for adjustment frame

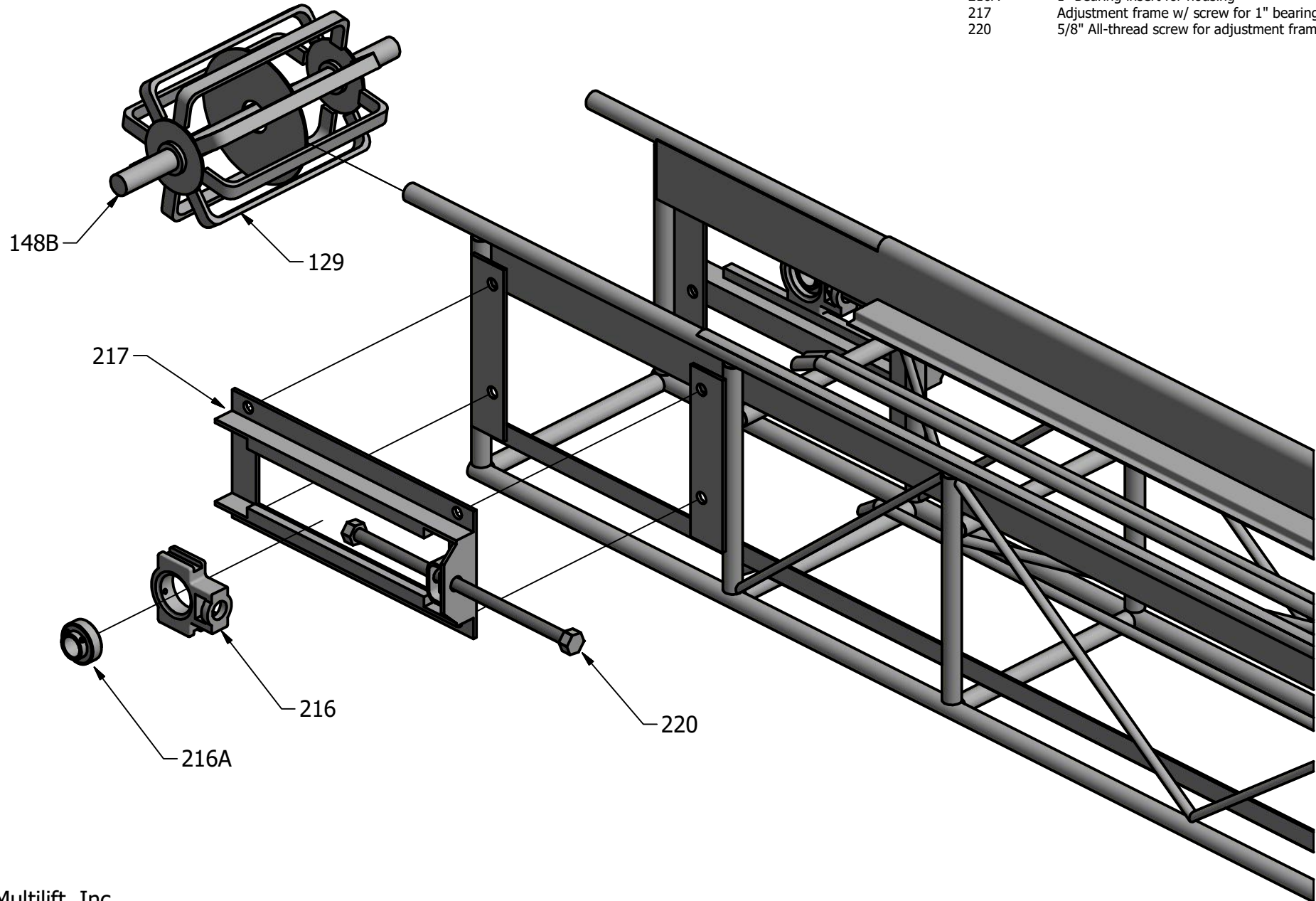

E-ZLIFT Top Side Mount 2" Belt Bucket Conveyor BB-050-TSM

Full Parts List Including Belting and Lacing

Part#	Description
156	Motor tension spring
156SC	Spring Clip
159	Motor Mount
168	2-1/2" O.D. x 1/2" bore B pulley (for electric motor)
170	2-1/2" O.D. x 5/8" bore B pulley (for gas engine)
179	11" O.D. x 5/8" bore v-belt Pulley
181	5L1000/B67 V-Belt
187	5-1/2 hp Honda gas engine
190A	V-Belt guard
193RB	1 hp 115V 56C TEFC rigid base motor
193TR	Thermal Reset Button for Baldor 1 hp 3510M motor
194RB	1-1/2 hp 115V 56C TEFC rigid base motor
194TR	Thermal Reset Button for Baldor 1-1/2 hp 3514M motor
202	2" Side Pan x 8 ft. long
Rubber cover	Rubber Cover for Thermal Reset

Part#	Description
129	Tail Pulley w/ 1" bore
148B	Tail Shaft w/ 1" O.D.
216	Adjustment housing w/ 1" bearing
216A	1" Bearing insert for housing
217	Adjustment frame w/ screw for 1" bearing
220	5/8" All-thread screw for adjustment frame

Belt Parts

Part#	Description
105	Bucket assembly
105A	2" belt strap for bucket
105B	Steel strap for 2" bucket
222	10" wide belting / ft.
325-M10-10	Set of 10" long Screw Lacing w/ 10mm screws
326-10	Set of #RS187 x 10" long Staple Lacing*

Complete Belt Assemblies w/ 2" Buckets

Part#	Description
205-12	12 ft. #28 conveyor
205	16 ft. #30 conveyor
206	21 ft. #31 conveyor
207	26 ft. #33 conveyor
208	31 ft. #35 conveyor
209	36 ft. #37 conveyor

* requires #326-4 tool for assembly

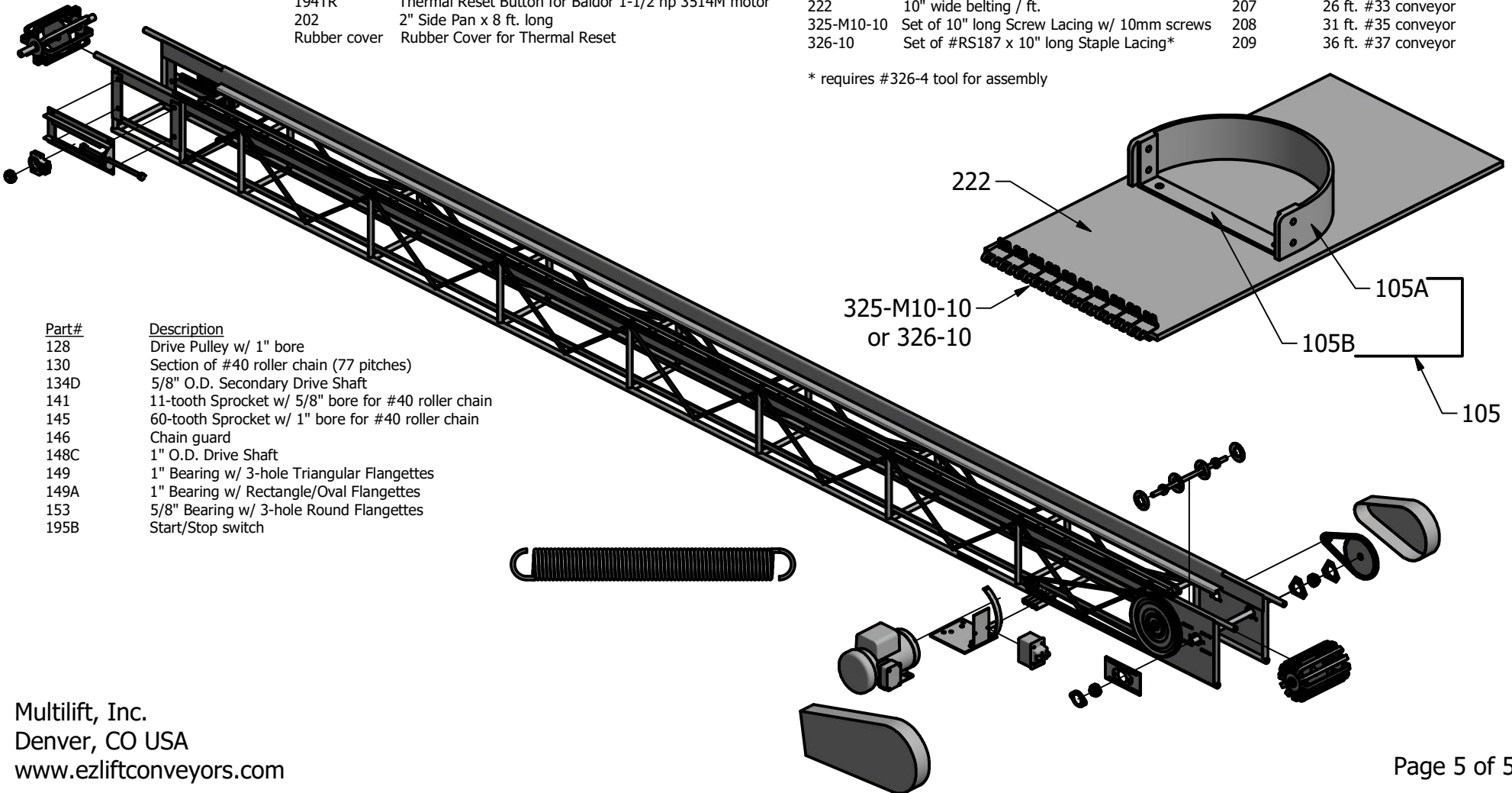

Part#	Description
128	Drive Pulley w/ 1" bore
130	Section of #40 roller chain (77 pitches)
134D	5/8" O.D. Secondary Drive Shaft
141	11-tooth Sprocket w/ 5/8" bore for #40 roller chain
145	60-tooth Sprocket w/ 1" bore for #40 roller chain
146	Chain guard
148C	1" O.D. Drive Shaft
149	1" Bearing w/ 3-hole Triangular Flangettes
149A	1" Bearing w/ Rectangle/Oval Flangettes
153	5/8" Bearing w/ 3-hole Round Flangettes
195B	Start/Stop switch