

Belt

Bucket

Models



The E-ZLIFT Belt Bucket model is a medium duty conveyor designed to move loose materials up to a 45° incline. The conveyor is lightweight and compact - it fits into basement windows and cellars.

Typical Uses Include:

Dirt, gravel, coal, dry sludge, recycling, and many bulk materials.

Features Include:

- 10" wide heavy duty 2-ply rubber belt with 2" or 4" deep rubber buckets on 24" centers and 2" or 4" steel side walls
- 7/8" O.D. high strength steel tubing truss frame - 1-1/4" O.D. on 36' model
- 15" Frame height
- Approximate 120 FPM belt speed
- Conveyor belt take-up adjustments
- Self-cleaning drive and idler belt pulleys
- Drive mounted at side of discharge end
- Electric motor or gas engine
- Start/Stop switch for electric motor
- For electric motor - direct drive speed reducer
- For gas engine - internal V-belt, roller chain reduction, and safety guards
- Fork pockets
- Operating, maintenance, and safety instructions

Accessories:

- Hopper
- Dolly and hitch assembly
- Tail-light assembly
- Towable elevating carriage

Options:

- Smooth belt
- Mini-cleated belt
- Straight cleats
- Forward/Stop/Reverse switch for electric motor

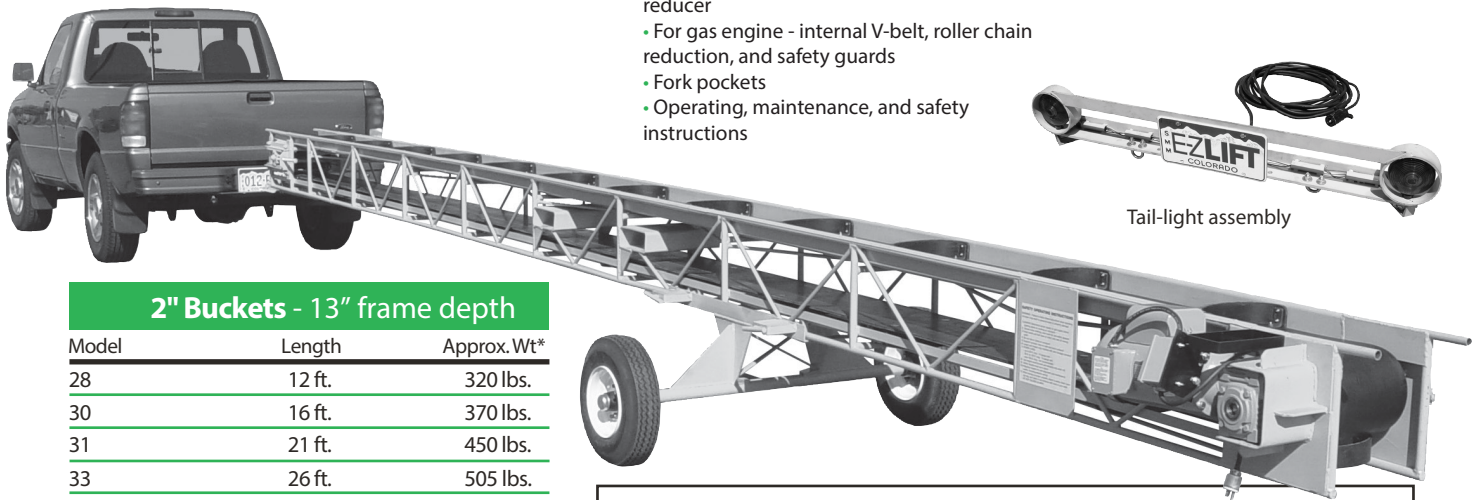

2" Buckets - 13" frame depth		
Model	Length	Approx. Wt*
28	12 ft.	320 lbs.
30	16 ft.	370 lbs.
31	21 ft.	450 lbs.
33	26 ft.	505 lbs.
35	31 ft.	575 lbs.
37	36 ft.	660 lbs.

4" Buckets - 19" frame depth		
Model	Length	Approx. Wt*
38	12 ft.	335 lbs.
40	16 ft.	385 lbs.
41	21 ft.	470 lbs.
43	26 ft.	530 lbs.
45	31 ft.	605 lbs.
47	36 ft.	695 lbs.

CAPACITY - 2" & 4" buckets		
Lbs./Cu. Ft.	Tons/Hr. @30° Incline	
	2"	4"
30	25	50
50	42	70
75	63	100

Specifications subject to change without notice
*Weight w/o accessories

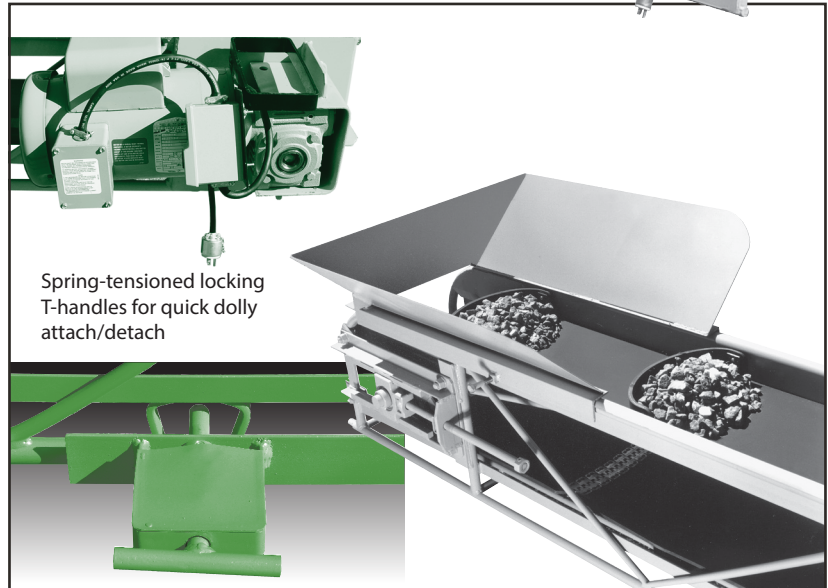

Multilift, Inc.

12410 W Cedar Dr, Lakewood, Colorado 80228
Denver Area: 303.733.5533 Fax: 303.733.5642
North American Toll Free: 1.800.821.9966

Email: ez@ezliftconveyors.com
Website: www.ezliftconveyors.com