

# **E-ZLIFT Troughing Roller Utility Conveyor TRU-050 SB**

**with Direct Drive for Smooth and Mini-Cleated 18" & 24" Wide Belts**

**Parts List & Schematic**

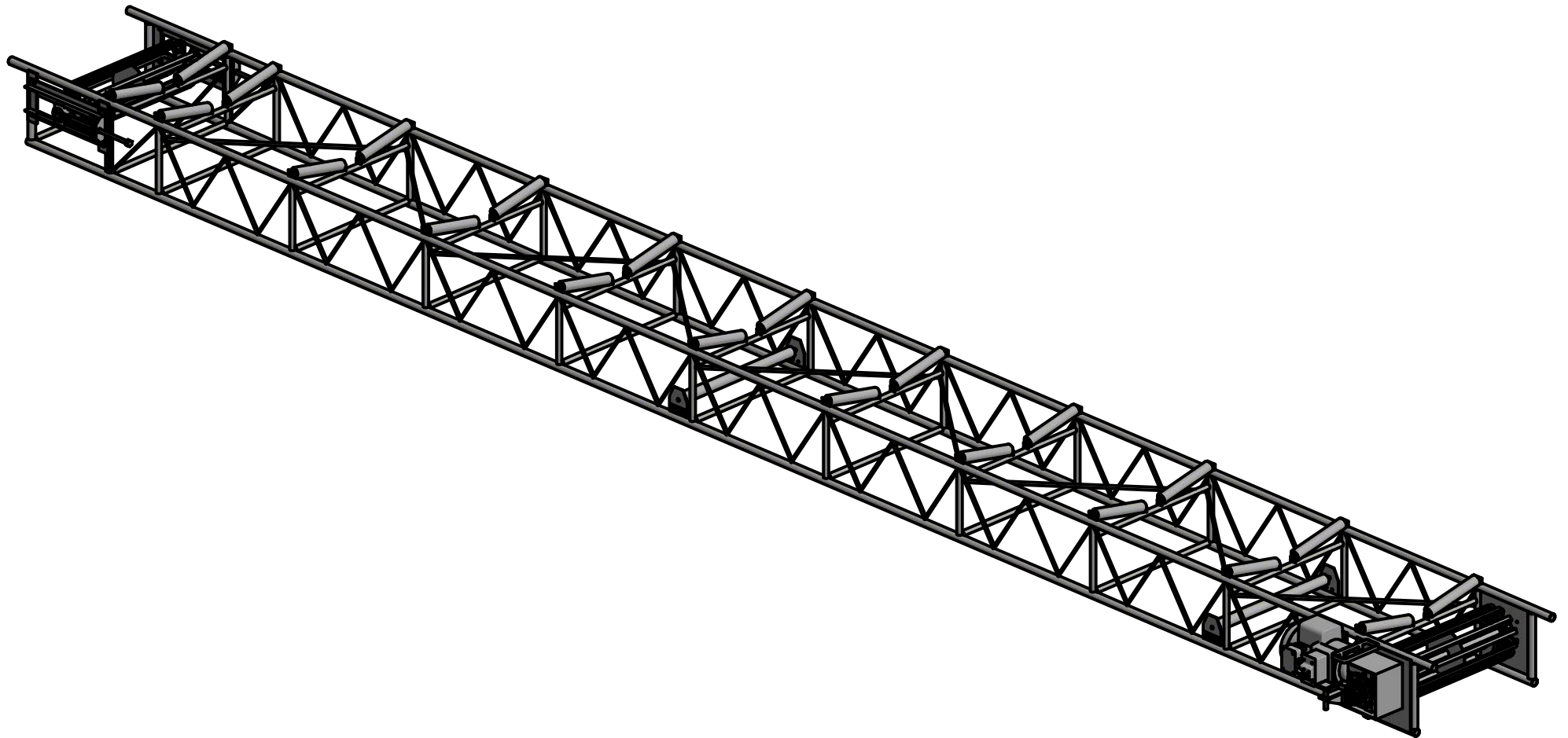

**Multilift, Inc.**

Denver, CO USA

[www.ezliftconveyors.com](http://www.ezliftconveyors.com)

North American Toll Free: 1-800-821-9966

Denver Local: 303-733-5533

**Model TRU-050 SB  
Driven End**

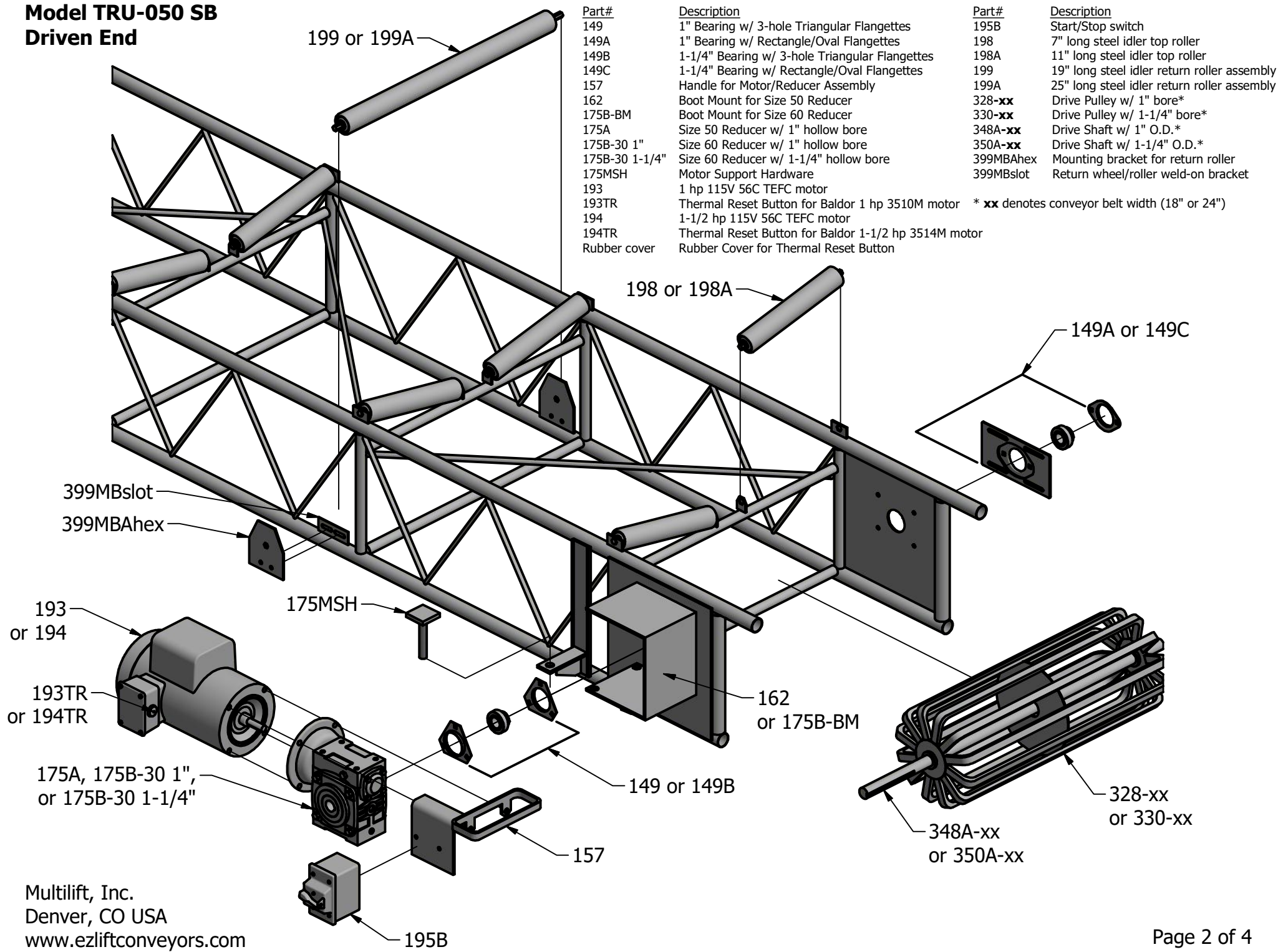

Part#	Description	Part#	Description
149	1" Bearing w/ 3-hole Triangular Flangettes	195B	Start/Stop switch
149A	1" Bearing w/ Rectangle/Oval Flangettes	198	7" long steel idler top roller
149B	1-1/4" Bearing w/ 3-hole Triangular Flangettes	198A	11" long steel idler top roller
149C	1-1/4" Bearing w/ Rectangle/Oval Flangettes	199	19" long steel idler return roller assembly
157	Handle for Motor/Reducer Assembly	199A	25" long steel idler return roller assembly
162	Boot Mount for Size 50 Reducer	328-xx	Drive Pulley w/ 1" bore*
175B-BM	Boot Mount for Size 60 Reducer	330-xx	Drive Pulley w/ 1-1/4" bore*
175A	Size 50 Reducer w/ 1" hollow bore	348A-xx	Drive Shaft w/ 1" O.D.*
175B-30 1"	Size 60 Reducer w/ 1" hollow bore	350A-xx	Drive Shaft w/ 1-1/4" O.D.*
175B-30 1-1/4"	Size 60 Reducer w/ 1-1/4" hollow bore	399MBAhex	Mounting bracket for return roller
175MSH	Motor Support Hardware	399MBslot	Return wheel/roller weld-on bracket
193	1 hp 115V 56C TEFC motor		
193TR	Thermal Reset Button for Baldor 1 hp 3510M motor		
194	1-1/2 hp 115V 56C TEFC motor		
194TR	Thermal Reset Button for Baldor 1-1/2 hp 3514M motor		
Rubber cover	Rubber Cover for Thermal Reset Button		

\* xx denotes conveyor belt width (18" or 24")

Multilift, Inc.  
Denver, CO USA  
www.ezliftconveyors.com

**Model TRU-050 SB  
Idle End**

Part#	Description
216	Adjustment housing w/ 1" bearing
216A	1" Bearing insert for housing
217	Adjustment frame w/ screw for 1" bearing
218	Adjustment housing w/ 1-1/4" bearing
218A	1-1/4" Bearing insert for housing
219	Adjustment frame w/ screw for 1-1/4" bearing
220	5/8" All-thread screw for adjustment frame
329-xx	Tail Pulley w/ 1" bore*
331-xx	Tail Pulley w/ 1-1/4" bore*
349-xx	Tail Shaft w/ 1" O.D.*
351-xx	Tail Shaft w/ 1-1/4" O.D.*

\* xx denotes conveyor belt width (18" or 24")

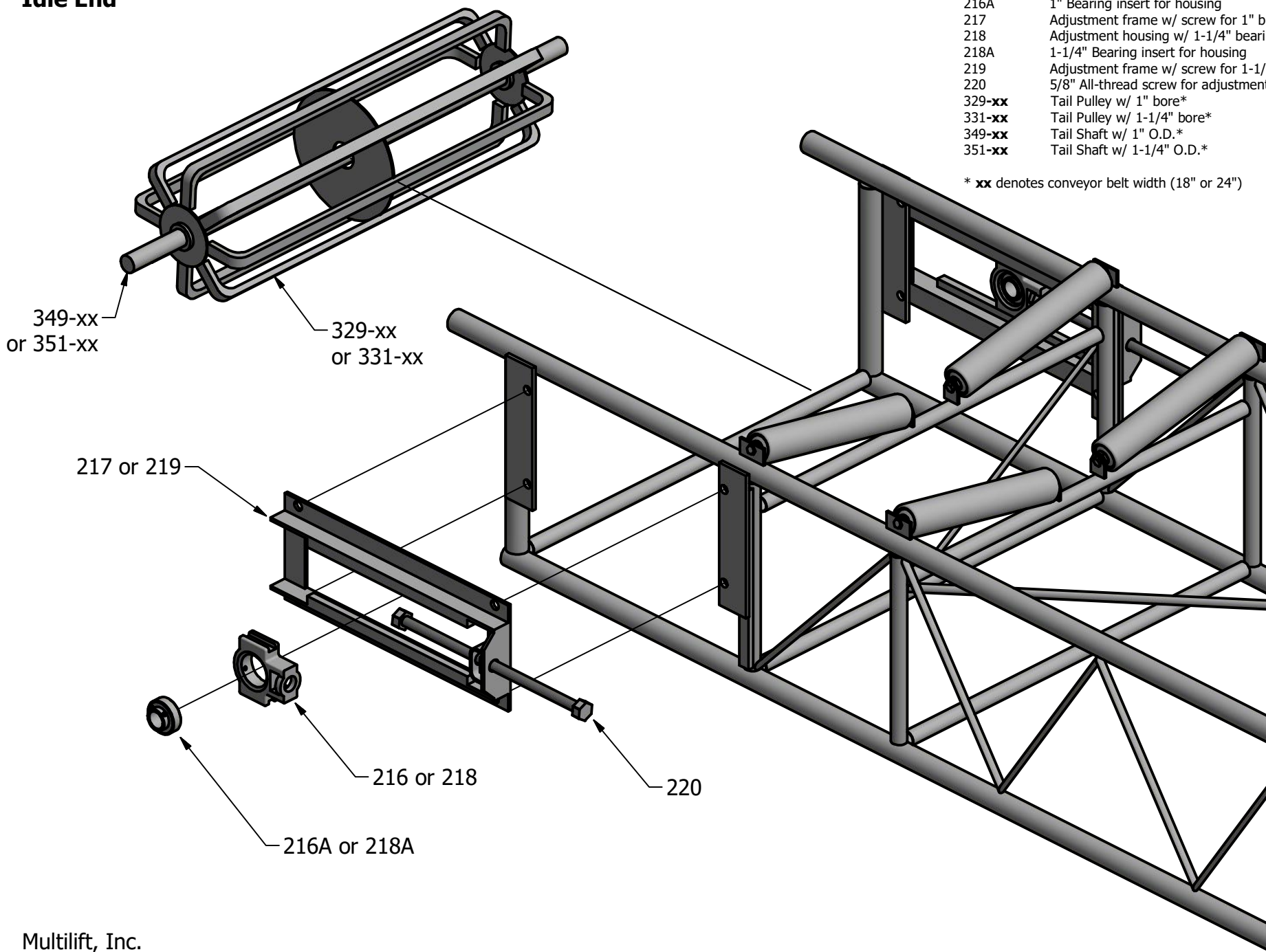

# E-ZLIFT Troughing Roller Utility Conveyor TRU-050 SB

## Full Parts List Including Belting and Lacing

Part#	Description
149	1" Bearing w/ 3-hole Triangular Flangettes
149A	1" Bearing w/ Rectangle/Oval Flangettes
149B	1-1/4" Bearing w/ 3-hole Triangular Flangettes
149C	1-1/4" Bearing w/ Rectangle/Oval Flangettes
157	Handle for Motor/Reducer Assembly
162	Boot Mount for Size 50 Reducer
175B-BM	Boot Mount for Size 60 Reducer
175A	Size 50 Reducer w/ 1" hollow bore
175B-30 1"	Size 60 Reducer w/ 1" hollow bore
175B-30 1-1/4"	Size 60 Reducer w/ 1-1/4" hollow bore
175MSH	Motor Support Hardware
193	1 hp 115V 56C TEFC motor
193TR	Thermal Reset Button for Baldor 1 hp 3510M motor
194	1-1/2 hp 115V 56C TEFC motor
194TR	Thermal Reset Button for Baldor 1-1/2 hp 3514M motor
Rubber cover	Rubber Cover for Thermal Reset Button

Part#	Description
195B	Start/Stop switch
198	7" long steel idler top roller
198A	11" long steel idler top roller
199	19" long steel idler return roller assembly
199A	25" long steel idler return roller assembly
328-xx	Drive Pulley w/ 1" bore*
330-xx	Drive Pulley w/ 1-1/4" bore*
348A-xx	Drive Shaft w/ 1" O.D.*
350A-xx	Drive Shaft w/ 1-1/4" O.D.*
399MBAhex	Mounting bracket for return roller
399MBSlot	Return wheel/roller weld-on bracket

Part#	Description
216	Adjustment housing w/ 1" bearing
216A	1" Bearing insert for housing
217	Adjustment frame w/ screw for 1" bearing
218	Adjustment housing w/ 1-1/4" bearing
218A	1-1/4" Bearing insert for housing
219	Adjustment frame w/ screw for 1-1/4" bearing
220	5/8" All-thread screw for adjustment frame
329-xx	Tail Pulley w/ 1" bore*
331-xx	Tail Pulley w/ 1-1/4" bore*
349-xx	Tail Shaft w/ 1" O.D.*
351-xx	Tail Shaft w/ 1-1/4" O.D.*

\* **xx** denotes conveyor belt width (18" or 24")

\* **xx** denotes conveyor belt width (18" or 24")

### Belt Parts

Part#	Description
222-xxs	-xx wide 2 ply 150 # 1/8" x 1/32" smooth belting / ft.*
323-xxmcb	-xx wide 2 ply 150 # 1/16" x B mini-cleated belting / ft.*
325-M7-xx	Set of -xx long Screw Lacing w/ 7mm screws for mini-cleated belts*
325-M10-xx	Set of -xx long Screw Lacing w/ 10mm screws for smooth belts*
326-xx	Set of #RS187 x -xx long Staple Lacing for smooth belts*, **
526-xx	Set of #RS125 x -xx long Staple Lacing for mini-cleated belts*, **

\* **xx** denotes conveyor belt width (18" or 24")

\*\* requires #326-4 tool for assembly

